

ELECON FLEXIBLE COUPLING

Elflex



ELECON 

Always a step ahead in technology

Flexible couplings transmit torque from one shaft to another and are particularly useful in cases where limited misalignment of shaft is unavoidable.

The quality of rubber used for bushes is of a special type which remains unaffected by water, dust and atmospheric conditions.

Elecon *Elflex* flexible couplings are cushioned drive type, transmitting the torque through rubber bushes which have excellent capacity to absorb shocks. The flanges are cast iron and are suitable for speeds up to the maximum limits as mentioned below.

Elecon *Elflex* flexible couplings are suitable for driving all classes of machinery.

The couplings work within the permissible limits of misalignment as per **IS : 2693** and **BS : 3170**.

ELECON - *Elflex* FLEXIBLE COUPLINGS

- ★ Permits drive in either direction.
- ★ Lubrication not required.
- ★ No adjustment after fitting.
- ★ Barrel shaped bushes ensure effective shocks and vibration absorption.
- ★ Low maintenance. and
- ★ Facility to dismantle machines simply by removing bolts and rubber bushes.

Flanges are bored to suit the requirement (see table for maximum bore) and key ways are to **DIN-6885, PART-1**; unless otherwise specified. Couplings can also be supplied with the minimum/pilot bore condition to permit machining at site.

SERVICE FACTOR TABLE			
Driven Machines	Service Factor		
	Type of driving unit		
	Electric motor or Steam Turbine	Steam engine or Water turbine	Gas or Oil engines
Even torque machines, smooth loads, centrifugal pumps, generators, line shafting, textile machines, screens, evaporators, etc.	1	1.25	2
Balancers, liner sets, coucres, machine tools, reeders, beaters, agitators, rotary dryers, light fan drives, blowers, stackers, rubber mixers, conveyors, intermittent loads, etc.	1.1	1.35	2.4
Heavy fan and blower drives, mine fans, cement mills, vacuum pumps, disintegrators, winders, wood working machines, copper and brass rolling mills, etc.	1.3	1.6	2.6
Calenders, compressors, paper drying, cylinders, cranes and hoists, planning machines, three-throw pumps, elevators, etc.	1.5	1.8	3
Tube and rolling mills, crushers, grinders, punch and shears, ball mills, pulverizers, double drum winders, dredgers, jordens, reversing and ship propulsion, etc.	2.2	2.4	3.4

➤ SELECTION FOR *Elflex* FLEXIBLE COUPLING

➤ Obtain Shaft Sizes

Compare shaft sizes of driving and driven equipment with listed bores of desired Series coupling to determine " Tentative " coupling size.

➤ Compute effective kW/rpm OR hp/rpm OR Torque to be transmitted select a service factor from above table,

Determine kW/rpm

$$\text{kW/rpm (effective)} = \frac{\text{kW TRANSMITTED} \times \text{SERVICE FACTOR}}{\text{rpm}}$$

OR determine hp/rpm

$$\text{hp/rpm (effective)} = \frac{\text{hp TRANSMITTED} \times \text{SERVICE FACTOR}}{\text{rpm}}$$

OR determine Toque (daNm)

$$\text{Torque (effective)} = \frac{955 \times \text{kW TRANSMITTED} \times \text{SERVICE FACTOR}}{\text{rpm}}$$

Confirm Tentative coupling size or increase to a size which has a rating equal to or greater than value computed above.

➤ Check Maximum Speed of Application Refer to maximum speed ratings. These speeds are given only as a guide since the maximum speed depends on the system characteristics.

➤ Check Space Limitations Dimensions of the selected coupling should be compared with space provided in the application to assure proper clearances. Shaft extensions (should be greater than the hub length of coupling), separation and clearances to align coupling as well as for removal of pins should be checked.

FEATURES

- Compact design.
- Low inertia.
- High torque to weight ratio.
- Low torque to bore ratio.
- Hexagonal headed pins for easy dismantling with standard spanners.

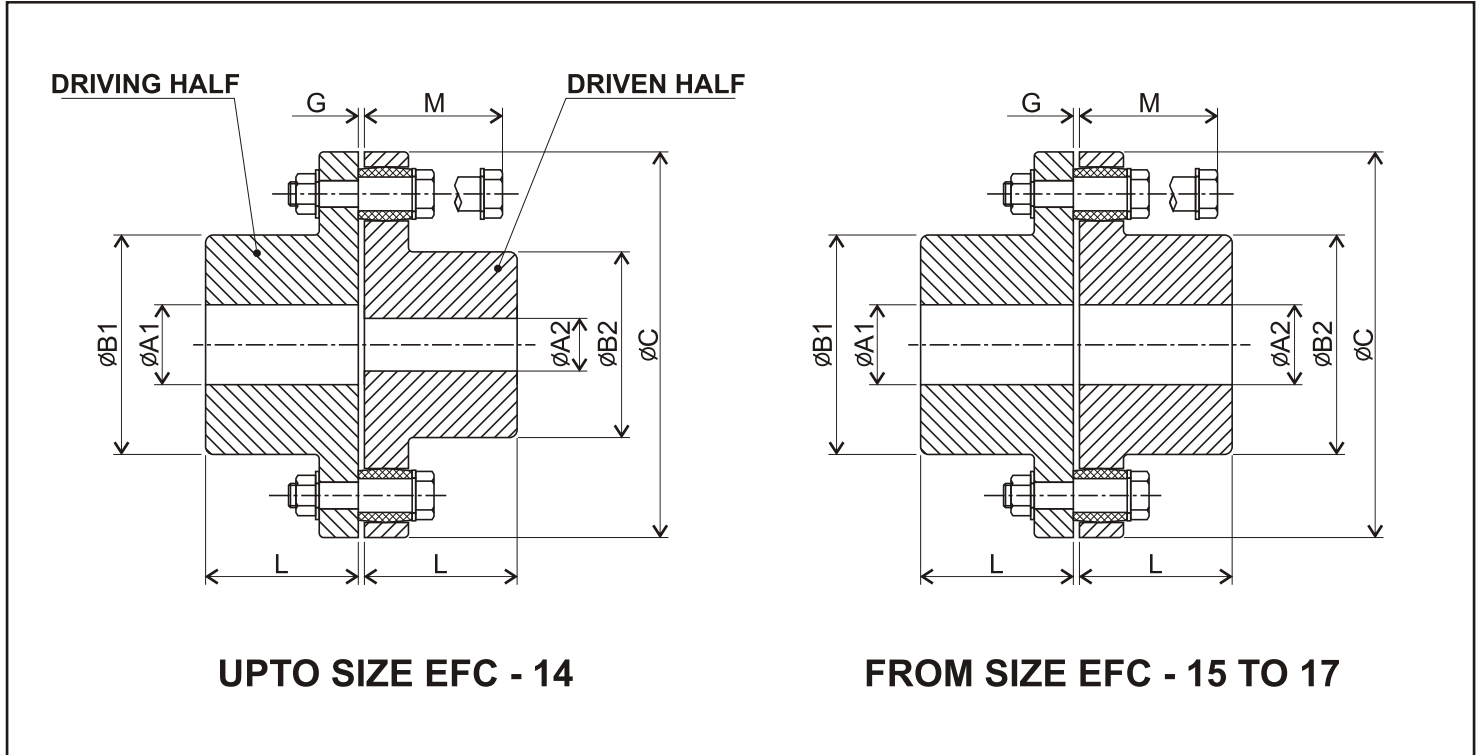

TECHNICAL DETAILS

SIZE	RATINGS		TORQUE daNm	PILOT BORE	MIN. BORE	MAX. BORE		ØC	ØB1	ØB2	L	G	M	NO. OF PINS	APP. WEIGHT (kg)	GD ² (kg.m ²)	MAX. SPEED (rpm)
	kW/rpm	hp/rpm				ØA1	ØA2										
EFC-01	0.007	0.01	7	12	16	32	28	85	48	42	32	03	50	04	1.5	0.004	7860
EFC-02	0.01	0.015	10.8	12	16	38	32	105	60	48	38	03	52	04	2.5	0.010	6360
EFC-03	0.022	0.029	21	12	16	42	40	112	63	60	42	03	52	05	3.0	0.014	5960
EFC-04	0.034	0.046	33	16	20	48	45	127	72	63	48	03	64	06	4.75	0.028	5260
EFC-05	0.056	0.075	53	16	20	55	50	144	82	75	55	03	64	08	7.0	0.048	4635
EFC-06	0.066	0.089	63.5	16	20	60	55	162	90	82	60	03	74	06	9.5	0.087	4120
EFC-07	0.091	0.122	87	16	20	70	65	180	105	98	70	03	74	08	12	0.143	3710
EFC-08	0.171	0.230	164	16	20	85	75	220	127	112	85	05	100	06	24	0.413	3035
EFC-09	0.214	0.288	205	16	20	95	85	240	140	128	95	05	100	08	31	0.612	2780
EFC-10	0.321	0.430	306	40	45	105	100	270	157	150	105	05	100	10	40	1.030	2475
EFC-11	0.383	0.513	365	40	45	110	105	285	162	155	110	05	126	08	50	1.540	2345
EFC-12	0.476	0.638	455	40	45	120	115	320	182	170	125	05	126	10	70	2.510	2085
EFC-13	0.638	0.855	609	40	45	130	125	340	196	185	140	06	152	08	92	3.9	1965
EFC-14	0.933	1.250	891	40	45	140	135	360	205	200	150	06	152	10	110	5	1855
EFC-15	1.262	1.700	1204	55	60	160	160	410	235	235	170	06	152	12	153	8.9	1630
EFC-16	1.948	2.610	1859	55	60	175	175	450	255	255	185	06	187	08	210	15.2	1480
EFC-17	2.835	3.800	2706	55	60	195	195	500	290	290	205	06	187	10	280	24.5	1335

- ★ ALL DIMENSIONS ARE IN mm.
- ★ WEIGHT AND MOMENT OF INERTIA BASED ON PILOT BORE CONDITION
- ★ CONTINUOUS TORQUE RATING SUBJECT TO ACCURATE ALIGNMENT OF CONNECTING SHAFTS.

In accordance with our established policy to constantly improve our products, the specifications contained herein are subject to change without notice.

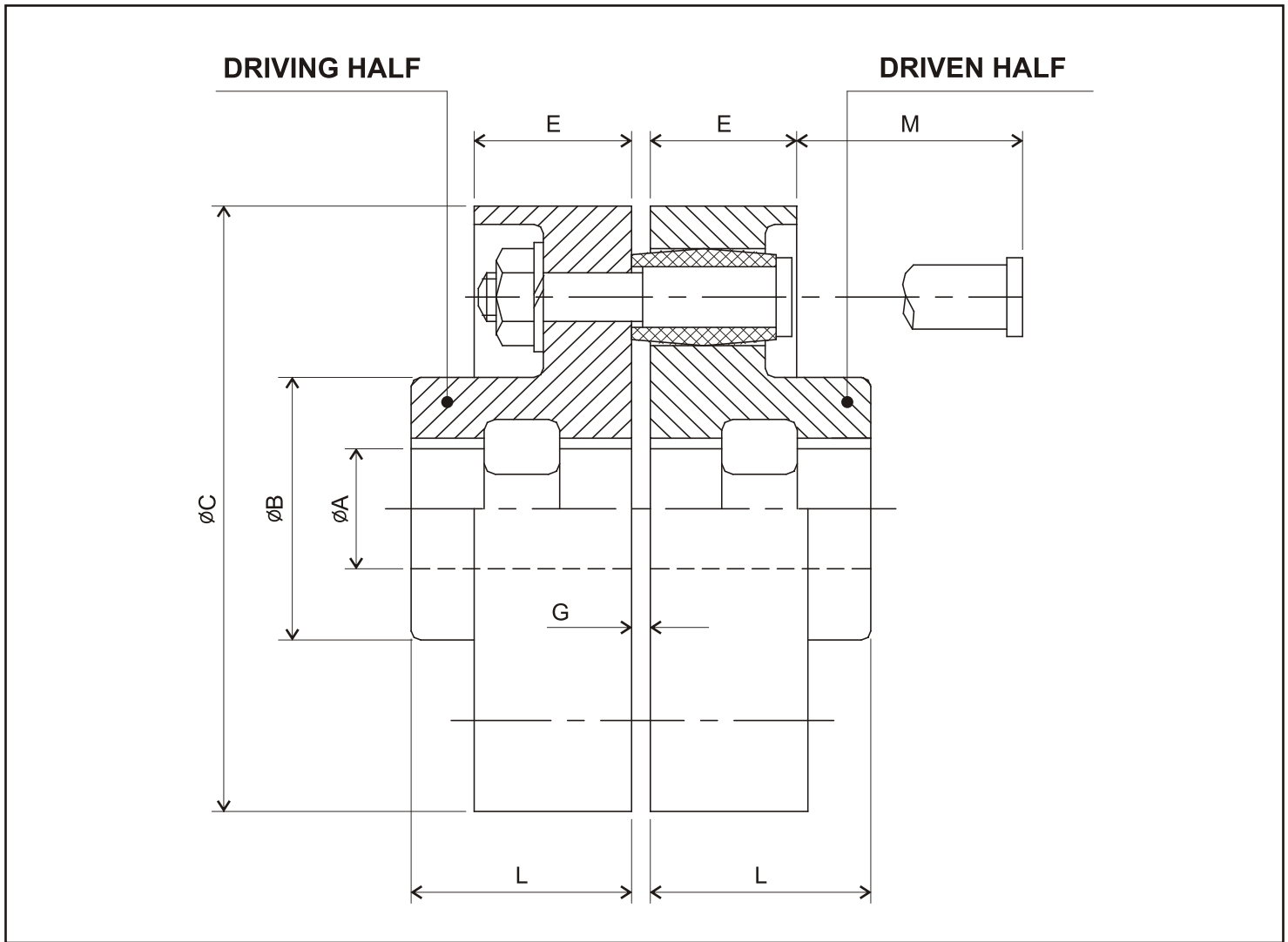

TECHNICAL DETAILS															
SIZE	RATING		TORQUE da Nm	BORE (ϕA)		ϕB	ϕC	L	E	M	G	No. of pins	Approx Weight (kg)	GD2 (kg.m ²)	Max. speed (rpm)
	kW/rpm	hp/rpm		Min	Max										
FC 630	3.35	4.5	3200	120	220	360	630	260	120	110	12 ₊₅	14	410	66	1050
FC 710	4.7	6.3	4500	120	240	390	710	280	135	130	12 ₊₅	18	560	114	940
FC 800	6.35	8.5	6100	120	260	430	800	300	135	130	12 ₊₅	18	750	187	850
FC 900	8.95	12	8600	140	290	480	900	320	152	150	12 ₊₅	12	990	308	750
FC 1000	12.68	17	12200	180	320	540	1000	350	152	150	14 ₊₆	16	1300	474	670
FC 1120	17.16	23	16500	230	350	590	1120	380	170	170	14 ₊₆	16	1700	824	600
FC 1250	23.88	32	23000	240	380	640	1250	420	170	170	14 ₊₆	20	2150	1272	530
FC 1400	33.58	45	32000	360	420	720	1400	460	195	190	14 ₊₆	14	3050	2213	480
FC 1600	44.77	60	43000	280	460	750	1600	500	195	190	14 ₊₆	20	3950	4163	430

- ★ ALL DIMENSIONS ARE IN mm.
- ★ WEIGHT AND MOMENT OF INERTIA BASED ON PILOT BORE CONDITION
- ★ CONTINUOUS TORQUE RATING SUBJECT TO ACCURATE ALIGNMENT OF CONNECTING SHAFTS.

In accordance with our established policy to constantly improve our products, the specifications contained herein are subject to change without notice.

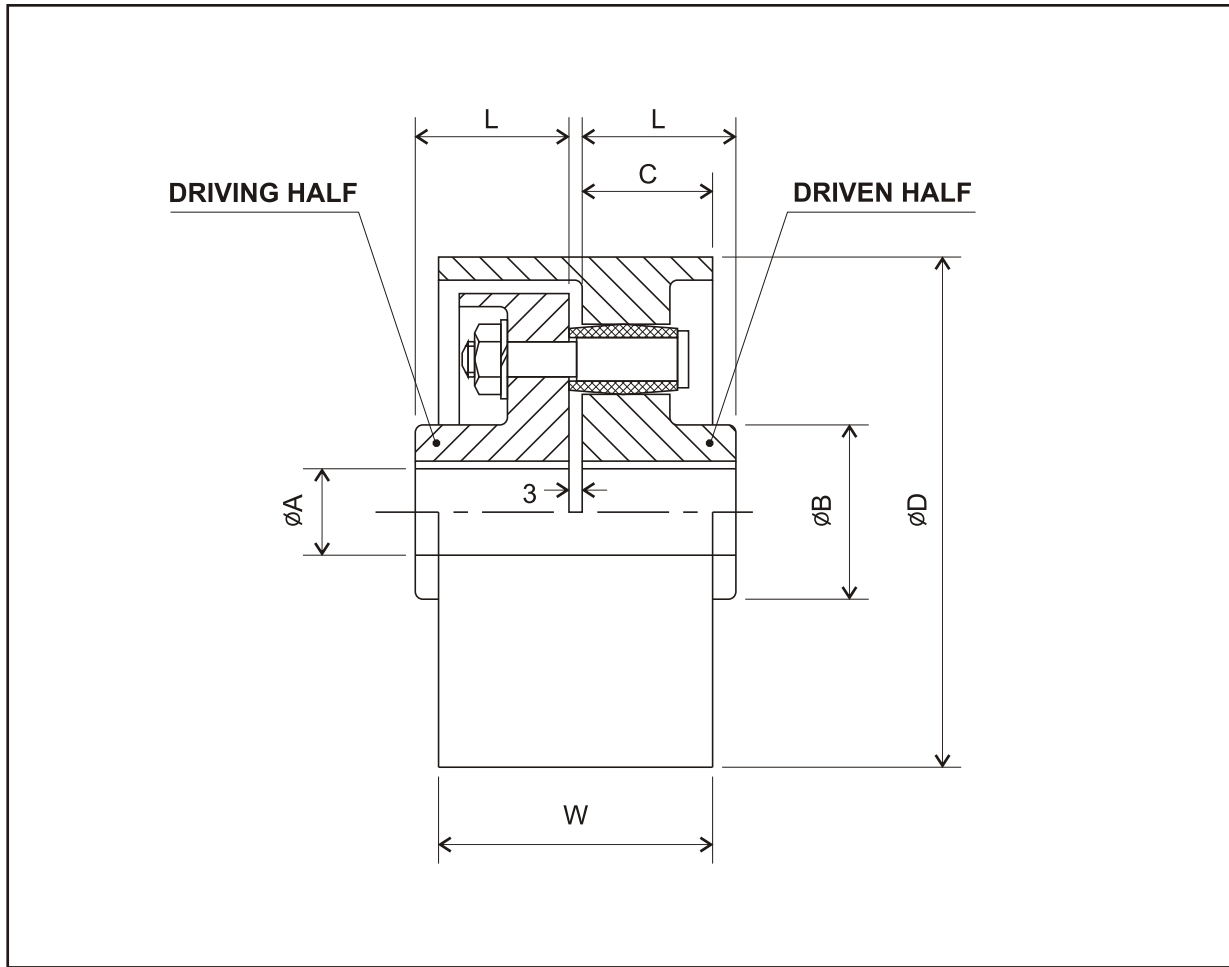
TECHNICAL DETAILS

SIZE	RATING hp/rpm	Nominal Torque daNm	BORE (øA)		øB	C	L	BRAKE DRUM		Approx weight (kg)	GD ² (kgm ²)	Maxi. speed (rpm)
			Mini	Maxi				øD	W			
FBC 100	0.016	12	16	25	40	40	32	100	75	3	0.015	5730
FBC 150	0.028	20	16	32	54	43	42	150	85	8	0.09	3830
FBC 160	0.030	22	16	32	54	43	42	160	85	9	0.13	3600
FBC 200	0.090	64	16	55	92	46	60	200	95	17	0.32	2870
FBC 250	0.125	90	16	60	105	60	75	250	120	25	1.0	2300
FBC 300	0.350	250	16	85	140	75	95	300	160	58	2.5	1910
FBC 315	0.420	300	16	85	140	75	95	315	160	62	2.85	1820
FBC 400	0.500	356	45	115	190.5	100	120.7	400	180	128	9.94	1440
FBC 450	0.630	450	45	115	190.5	100	120.7	450	200	165	15.4	1270
FBC 500	1.380	983	45	135	235	112.5	146	500	225	244	27.5	1150

- ★ ALL DIMENSIONS ARE IN mm.
- ★ WEIGHT AND MOMENT OF INERTIA BASED ON PILOT BORE CONDITION
- ★ CONTINUOUS TORQUE RATING SUBJECT TO ACCURATE ALIGNMENT OF CONNECTING SHAFTS.

In accordance with our established policy to constantly improve our products, the specifications contained herein are subject to change without notice.